

GENERAL NOTES

- THIS INFORMATION CONFORMS TO ALL APPLICABLE STANDARDS FOR FIRE TRAINING SIMULATORS AT THE TIME OF PREPARATION.
- THE ERECTION CONTRACTOR ASSUMES RESPONSIBILITY FOR ALL MATERIALS, AT THE TIME OF DELIVERY. THIS CONTRACTOR IS ALSO RESPONSIBLE TO ACCOUNT FOR ALL MATERIAL, AT TIME OF DELIVERY. IF THERE IS A DISCREPANCY IN THE MATERIAL DELIVERED, CONTACT WHP TRAININGTOWERS IMMEDIATELY IN ORDER TO MAKE PROPER ARRANGEMENTS TO PROVIDE THE NECESSARY MATERIAL.
- THIS SET OF DRAWINGS IS INTENDED AS A CONCEPTUAL SET, PROVIDED FOR SECONDARY REFERENCE ONLY. REFER TO BEHLEN INDUSTRIES CONSTRUCTION DRAWINGS AND THE MISCELLANEOUS METALS DRAWINGS AS PRIMARY REFERENCE FOR EXACT MATERIAL DIMENSIONS, ERECTION, AND PROCEDURES.
- THESE DRAWINGS, SPECIFICATIONS, IDEAS, DESIGNS, AND ARRANGEMENTS ARE AND SHALL REMAIN THE PROPERTY OF WHP TRAININGTOWERS AND NO PART THERE OF SHALL BE COPIED, REPRODUCED, OR USED IN CONNECTION WITH ANY WORK OR PROJECT OTHER THAN THE SPECIFIC PROJECT FOR WHICH THEY HAVE BEEN PREPARED WITHOUT WRITTEN CONSENT FROM WHP TRAININGTOWERS.
- WRITTEN DIMENSIONS ON THESE DRAWINGS SHALL TAKE PRECEDENCE OVER SCALED DIMENSIONS. INSTALLING CONTRACTORS OR OWNERS SHALL VERIFY AND BE RESPONSIBLE FOR ALL DIMENSIONS AND CONDITIONS ON THE JOB AND WHP TRAININGTOWERS SHALL BE NOTIFIED IMMEDIATELY OF ANY VARIATIONS OR DISCREPANCIES FROM THE DIMENSIONS AND CONDITIONS SHOWN BY THESE DRAWINGS. ANY FIELD CHANGES OR MODIFICATIONS TO EITHER THE STRUCTURE OR ADDITIVE COMPONENTS MUST BE REPORTED AND APPROVED BY WHP TRAININGTOWERS PRIOR TO PERFORMING ANY WORK.
- MISCELLANEOUS FIELD CUTTING AND FITTING OF BOTH STRUCTURAL AS WELL AS LIGHT GAUGE FRAMING COMPONENTS WILL BE NECESSARY TO BE ABLE TO PERFORM THE INSTALLATION AND RECEPTION WITH ANY WORK UNDER STANDARD CONDITION AND REQUIREMENT FOR ERECTION OF THIS LIVE FIRE TRAINING SIMULATOR AND ITS COMPONENTS.
- DOORS SHALL BE PAINTED 18 GA HOT-DIPPED GALVANIZED HOLLOW METAL SLABS WITH CONTINUOUSLY WELDED SEAMS. DOOR FRAMES SHALL BE 1" PAINTED 16 GA HOT-DIPPED GALVANIZED FRAMES. EACH EXTERIOR NON-BURN ROOM DOOR SHALL BE PROVIDED WITH (1) HEAVY-DUTY STAINLESS STEEL BALL BEARING HINGES, (1) COMMERCIAL GRADE KEYED LOCKSET, AND (2) DOOR MUTES. EACH INTERIOR NON-BURN ROOM DOOR SHALL BE PROVIDED WITH (3) HEAVY-DUTY STAINLESS STEEL BALL BEARING HINGES, (1) COMMERCIAL GRADE PASSAGE SET, AND (2) DOOR MUTES. EACH BURN ROOM DOOR SHALL BE PROVIDED WITH (3) HEAVY-DUTY STAINLESS STEEL BALL BEARING HINGES, (2) SPRING-TYPE CLOSING DEVICES, (1) DOOR PULL, (1) ADJUSTABLE BALL CATCH, AND (1) 8" LOCKABLE BARREL BOLT FOR USE IN SECURING THE BUILDING WHEN NOT IN USE. ANY DOUBLE DOORS SHALL BE PROVIDED WITH (1) METAL DISTRICT ALL DOOR FRAMES THAT DO NOT SIT ON THE CONCRETE STEM WALL SHALL EXTEND 6" FROM THE BOTTOM OF DOOR SLAB. ALL DOORS SHALL HAVE (1) HIGH-TEMP DOOR SWEEP INSTALLED ON THE OUTSIDING SIDE OF THE DOOR. THE DOOR SWEEP SHALL DRAG AGAINST THE FINISHED FLOOR LEVEL.
- WINDOW CLOSURES SHALL BE PAINTED 12 GA HOT-DIPPED GALVANIZED SINGLE LEAVES WITH A 1" DEEP PAN FRAME DESIGN. EACH NON-BURN ROOM CLOSURE ACCESSIBLE FROM THE GROUND SHALL BE PROVIDED WITH (1) STAINLESS STEEL CONTINUOUS HINGE, (1) SLAM LATCH, (1) KEYED LEVER ON THE EXTERIOR SIDE OF THE CLOSURE, AND (1) PASSAGE LEVER ON THE INTERIOR SIDE OF THE CLOSURE. EACH NON-BURN ROOM CLOSURE NOT ACCESSIBLE FROM THE GROUND SHALL BE PROVIDED WITH (1) STAINLESS STEEL CONTINUOUS HINGE, (1) SLAM LATCH, (1) PASSAGE LEVER ON THE EXTERIOR SIDE OF THE CLOSURE, AND (1) PASSAGE LEVER ON THE INTERIOR SIDE OF THE CLOSURE. EACH BURN ROOM CLOSURE SHALL BE PROVIDED WITH ONE OF THE ABOVE HARDWARE SETS AND SHALL INCLUDE (3) "PADGENTIE" MOUNTING CHANNELS WELDED ON THE INTERIOR SIDE OF THE CLOSURE. ALL CLOSURES SHALL BE INSTALLED WITH EQUAL SPACING BETWEEN THE FRAMED OPENING AND THE CLOSURE PAN. ALL SILL ELEVATIONS SHALL BE 42" ABOVE FINISHED FLOOR ELEVATION.
- FLOOR DECKS ABOVE GRADE SHALL BE CONCRETE OVER GALVANIZED 1.5" "C" DECK FASTENED DIRECTLY TO FLOOR JOISTS USING SELF-DRILLING/SELF-THREADING TEK SCREW FASTENERS AT 6" O.C. INCREMENTS. ALL FLOOR DECKS SHALL REQUIRE FIELD CUTTING AND FITTING AS REQUIRED TO ACCOMMODATE THE BUILDING CONFIGURATION. CONCRETE FILL SHALL BE 4" IN DEPTH. CONCRETE SHALL BE A SMALL AGGREGATE CONCRETE WITH FIBER MESH REINFORCING. CONCRETE SHALL BE PITCHED TO EXTERIOR WALLS AND DOOR OPENINGS. FINISH SHALL BE A LIGHT BROOM FINISH. (CONCRETE FILL BY OTHERS)
- ALL CORRUGATED ROOF AND WALL PANELS ARE TO BE PREFINISHED IN ONE OF 13 STANDARD COLORS. COMPOUND CORRUGATED WALL PANELS ARE 3'-5" WIDE AND 4 1/2" DEEP. COMPOUND CORRUGATED ROOF PANELS ARE TO BE 3'-5" WIDE AND 7 1/2" DEEP. ALL WALL AND ROOF PANELS ARE TO BE BOLTED AT 6" O.C. INCREMENTS UTILIZING 3/8" DIAMETER BOLT FASTENERS PROVIDED IN A COLOR TO MATCH THE WALL OR ROOF PANEL COLOR.
- ALL INTERIOR WALL PARTITIONS SHALL BE CONSTRUCTED OF 4 1/2" X 18 GA GALVANIZED METAL STUDS AT 24" O.C. AND 4 1/2" X 18 GA GALVANIZED METAL TRACK. ALL SIDES OF INTERIOR PARTITIONS NOT RECEIVING BURN ROOM PANELS SHALL RECEIVE 18 GA GALVANIZED SHEETING FASTENED WITH #8 X 3/8" LOW PROFILE TEK SCREWS AT 12" O.C.

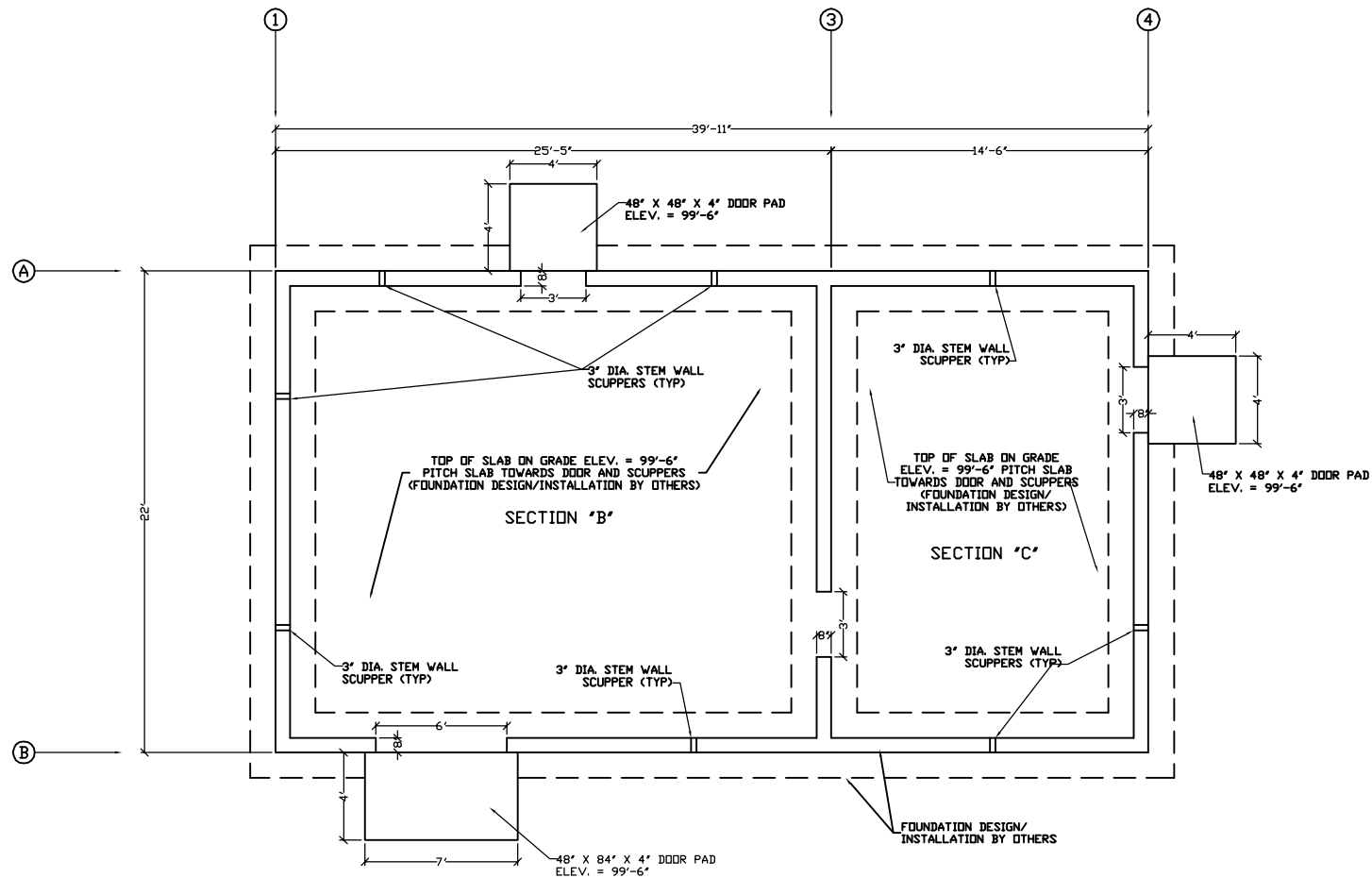

CONCEPTUAL FOUNDATION LAYOUT  
NOT TO SCALE

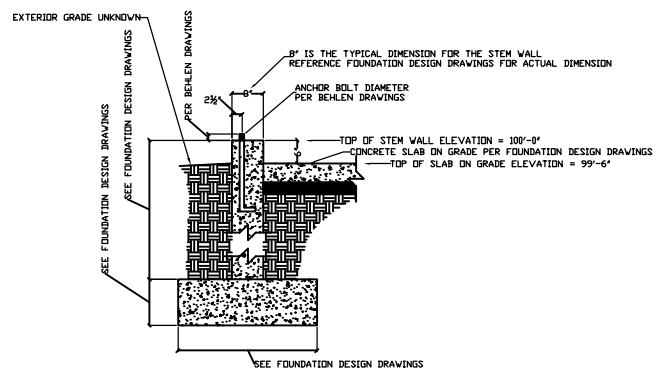

ANCHOR BOLT DETAIL (TYP.)  
NOT TO SCALE

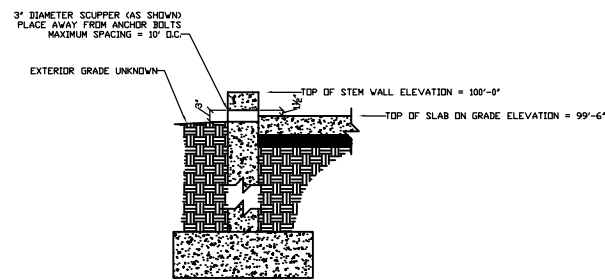

WALL SCUPPER DETAIL (TYP.)  
NOT TO SCALE

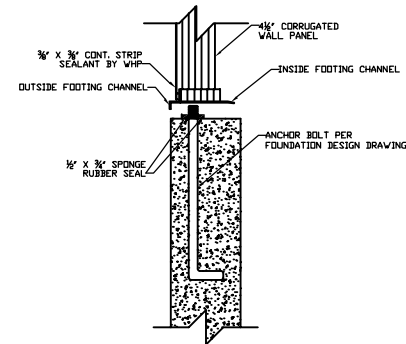

FOUNDATION CHANNEL DETAIL (TYP.)  
NOT TO SCALE

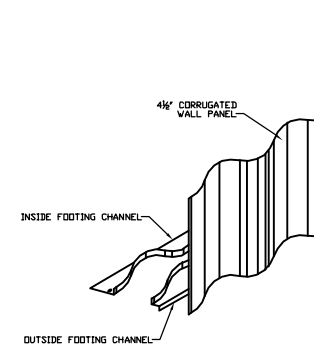

WALL PANEL DETAIL (TYP.)  
NOT TO SCALE

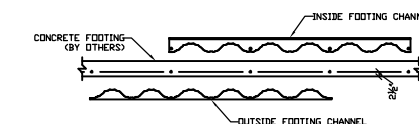

ERECTION NOTE - STAGGER CHANNEL AS SHOWN  
NOT TO SCALE

2ND ALARM - STANDARD  
FIRE TRAINING SIMULATOR

FIRE DEPARTMENT TRAINING SIMULATOR

THIS INFORMATION CONFORMS TO ALL APPLICABLE STANDARDS FOR THE TRAINING SIMULATORS AT THE TIME OF PREPARATION.  
THE ERECTION CONTRACTOR ASSUMES RESPONSIBILITY FOR ALL MATERIALS, AT TIME OF DELIVERY. THIS CONTRACTOR IS ALSO RESPONSIBLE TO ACCOUNT FOR ALL MATERIAL, AT TIME OF DELIVERY. IF THERE IS A DISCREPANCY IN THE MATERIAL DELIVERED, CONTACT WHP TRAININGTOWERS IMMEDIATELY IN ORDER TO MAKE PROPER ARRANGEMENTS TO PROVIDE THE NECESSARY MATERIAL.  
THIS SET OF DRAWINGS IS INTENDED AS A CONCEPTUAL SET, PROVIDED FOR SECONDARY REFERENCE ONLY. REFER TO BEHLEN INDUSTRIES CONSTRUCTION DRAWINGS AND THE MISCELLANEOUS METALS DRAWINGS AS PRIMARY REFERENCE FOR EXACT MATERIAL DIMENSIONS, ERECTION, AND PROCEDURES.  
THESE DRAWINGS, SPECIFICATIONS, IDEAS, DESIGNS, AND ARRANGEMENTS ARE AND SHALL REMAIN THE PROPERTY OF WHP TRAININGTOWERS AND NO PART THERE OF SHALL BE COPIED, REPRODUCED, OR USED IN CONNECTION WITH ANY WORK OR PROJECT OTHER THAN THE SPECIFIC PROJECT FOR WHICH THEY HAVE BEEN PREPARED WITHOUT WRITTEN CONSENT OF WHP TRAININGTOWERS.

PROJECT NUMBER:	00-W-000	REVISION DATES:
PROJECT ERECTOR:	PK 2	
DRAWN BY:	PK 3	
REVIEWED BY:		
PRINT DATE:	00-00-00	

FOUNDATION PLAN

www.trainingtowers.com

A DIV. OF J.S.C. INC

9121 BOND OVERLAND PARK, KS 66214  
TEL 913-365-3663 FAX: 913-365-7078  
TOLL FREE 1-800-351-2525 www.trainingtowers.com

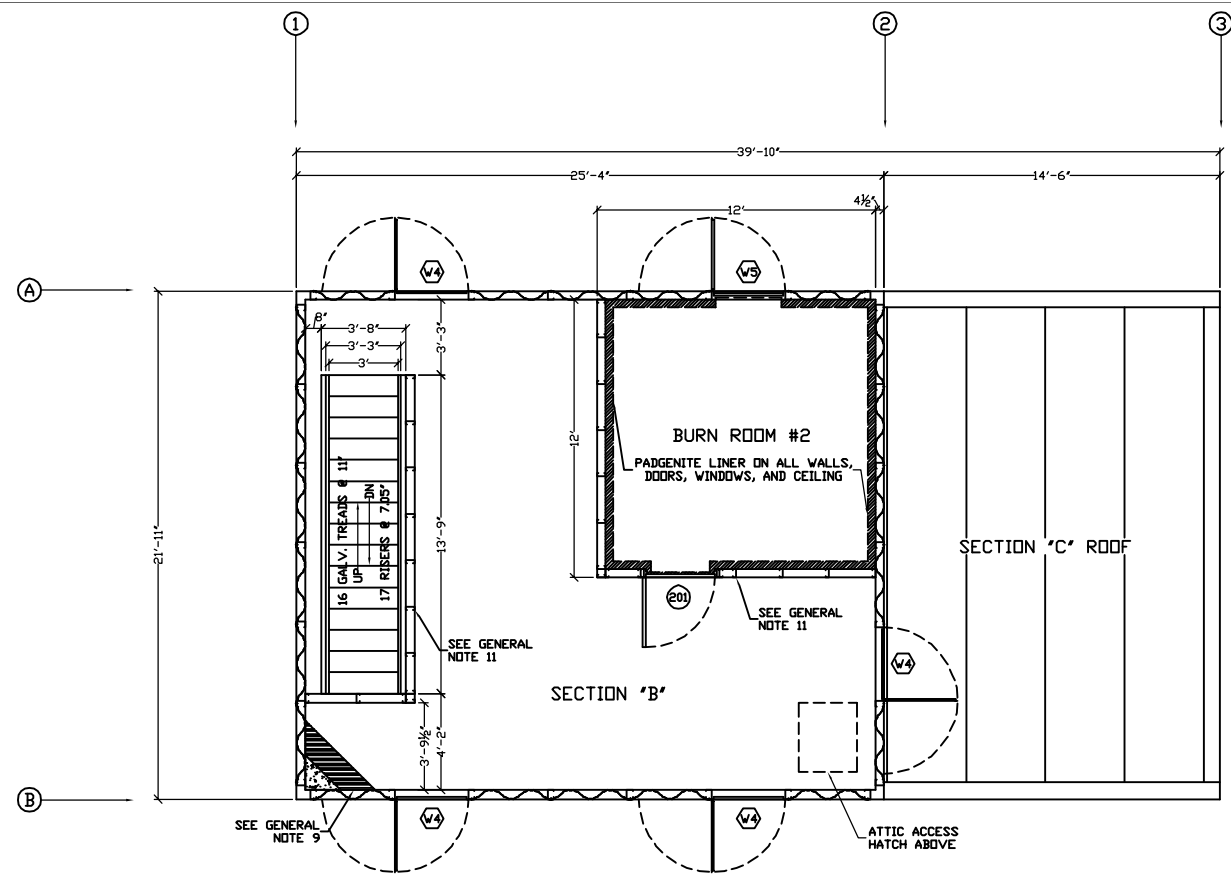

2ND FLOOR PLAN AND ANNEX ROOF PLAN  
NOT TO SCALE

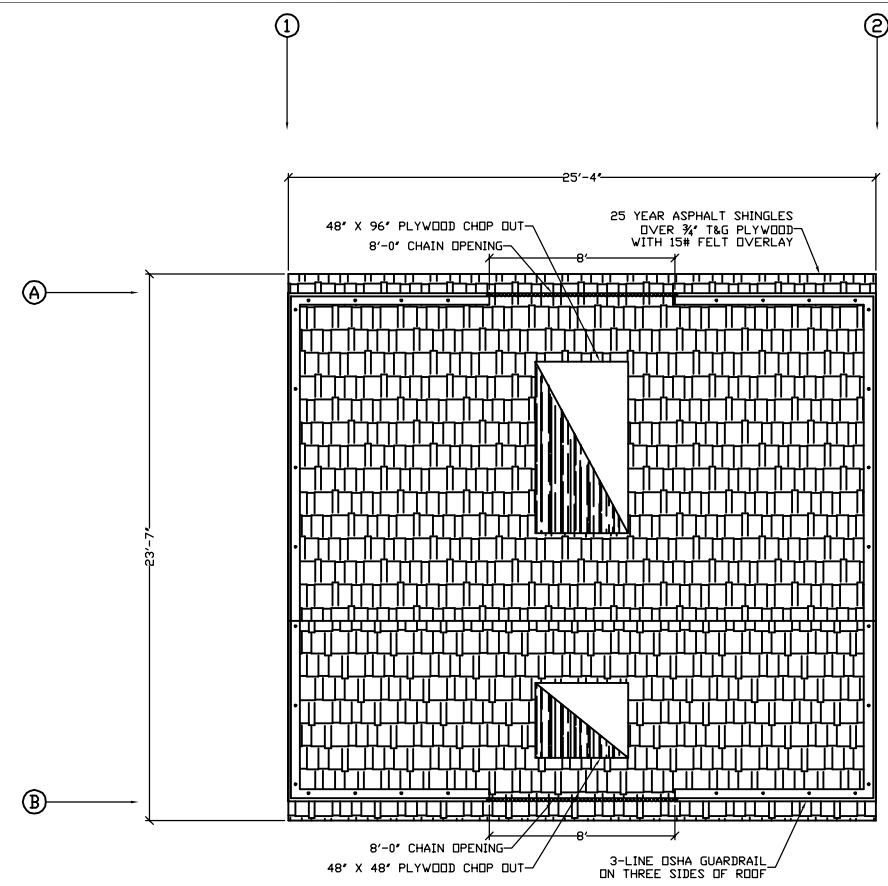

RESIDENTIAL ROOF PLAN  
NOT TO SCALE

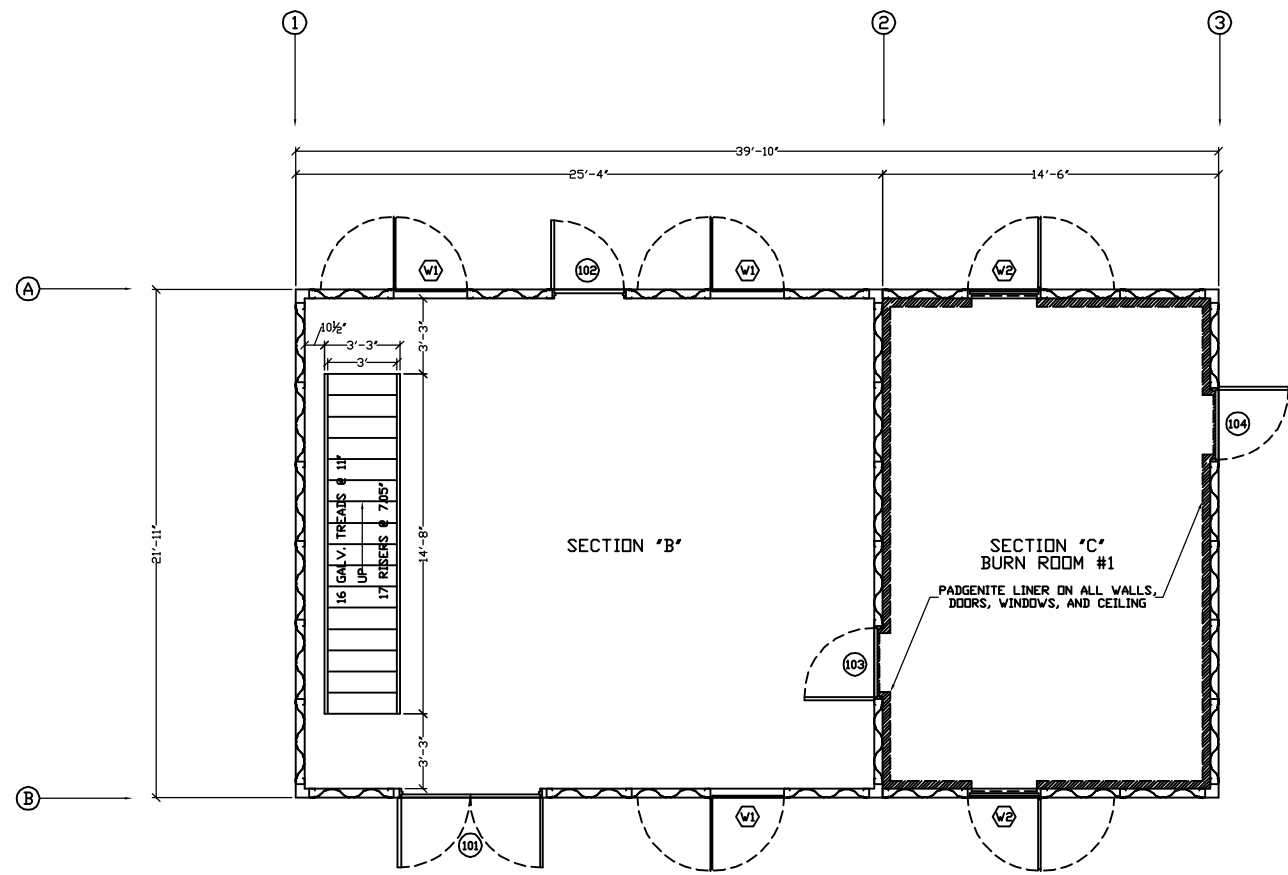

RESIDENTIAL AND ANNEX 1ST FLOOR PLAN  
NOT TO SCALE

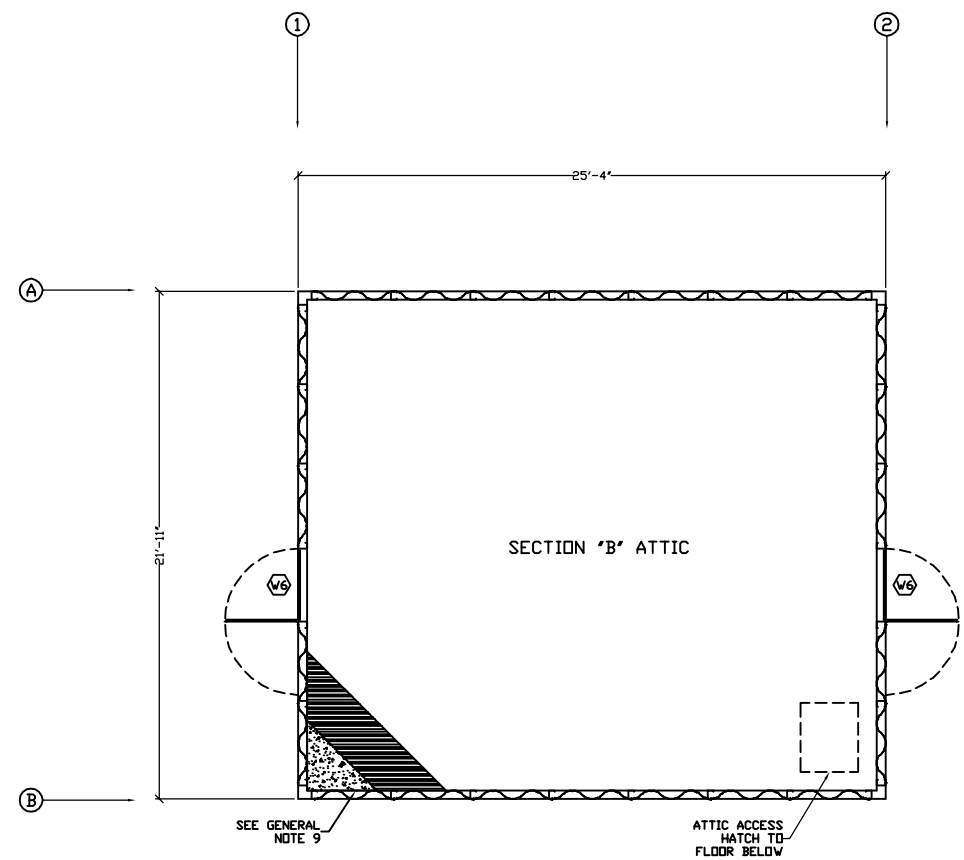

RESIDENTIAL ATTIC PLAN  
NOT TO SCALE

**2ND ALARM - STANDARD  
FIRE TRAINING SIMULATOR**

FIRE DEPARTMENT TRAINING SIMULATOR

THIS INFORMATION CONFORMS TO ALL APPLICABLE STANDARDS FOR THE TRAINING SIMULATORS AT THE TIME OF REVISION.  
THE DESIGN CONTRACTOR ASSUMES RESPONSIBILITY FOR ALL MATERIALS, AT THE TIME OF DESIGN. HIS CONTRACTOR IS ALSO RESPONSIBLE TO ACCOUNT FOR ALL MATERIALS, AT THE TIME OF REVISION. IF THERE IS A DISCREPANCY IN THE MATERIAL REVISIONS, CONTACT THE MANUFACTURERS IMMEDIATELY IN ORDER TO MAKE PROPER ARRANGEMENTS TO PROVIDE THE NECESSARY MATERIAL.  
THIS SET OF DRAWINGS IS INTENDED AS A CONCEPTUAL SET, PROVIDED FOR SECONDARY REFERENCE ONLY. REFER TO MANUFACTURER'S CONSTRUCTION DRAWINGS AND THE MANUFACTURER'S DETAIL DRAWINGS AS PRIMARY REFERENCE FOR EXACT MATERIAL DIMENSIONS, DECIMALS, AND PROCEDURES.  
THESE DIMENSIONS, SPECIFICATIONS, REVISIONS, AND ARRANGEMENTS ARE AND SHALL REMAIN THE PROPERTY OF WFP TRAINING TOWERS AND NO PART THEREOF SHALL BE COPIED, REPRODUCED, OR USED IN CONNECTION WITH ANY WORK OR PROJECT OTHER THAN THE SPECIFIC PROJECT FOR WHICH THEY HAVE BEEN PREPARED WITHOUT THE WRITTEN CONSENT OF WFP TRAINING TOWERS.

PROJECT NUMBER:	00-W-000	REVISION DATES:
PROJECT DIRECTOR:	JPK	2
DRAWN BY:	JP	3
REVIEWED BY:		4
PRINT DATE:	00-00-00	

FLOOR PLANS

trainingtowers.com  
wfp  
A DIV. OF J.S.C. INC.  
9121 BOND OVERLAND PARK, KS 66214  
TEL 913-365-3663 FAX: 913-365-7078  
TOLL FREE 1-800-351-2525 www.trainingtowers.com

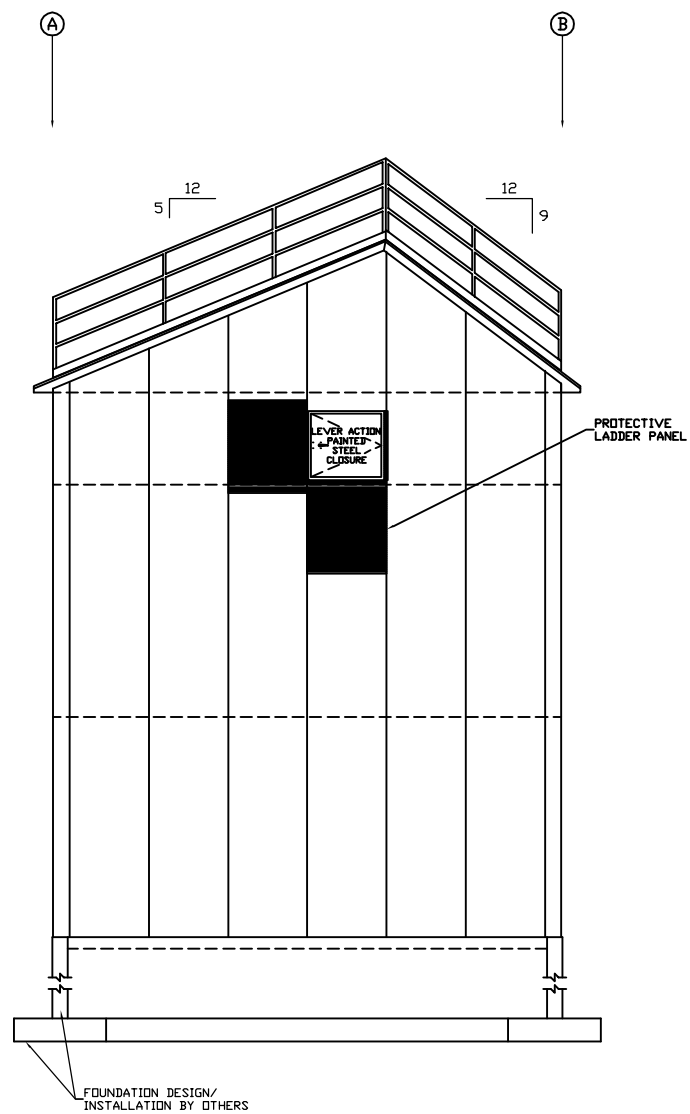

LEFT SIDE ELEVATION  
NOT TO SCALE

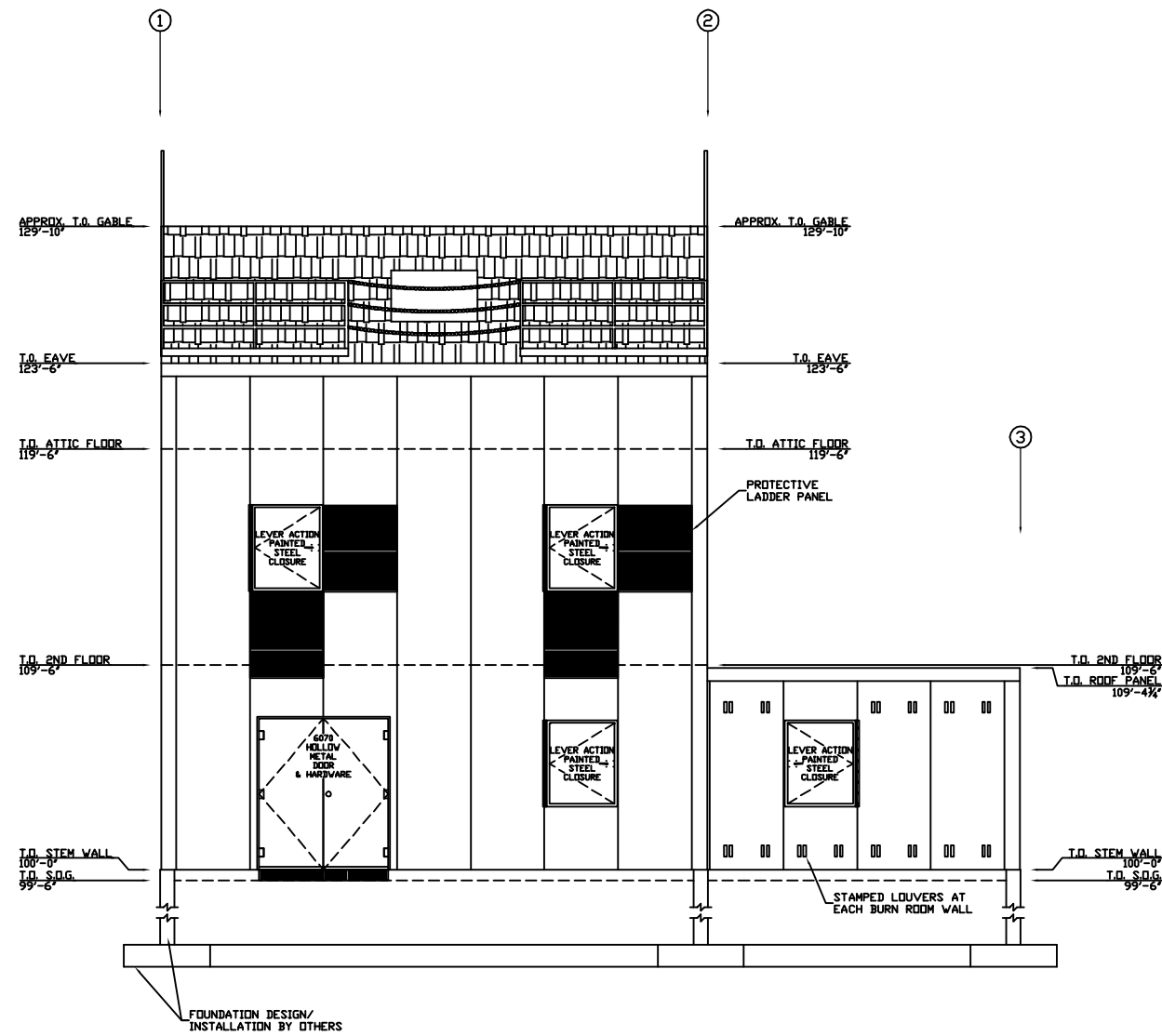

FRONT SIDE ELEVATION  
NOT TO SCALE

www.trainingtowers.com  
A DIV. OF J.S.C. INC.  
9121 BOND OVERLAND PARK, KS 66214  
TEL 913-365-3663 FAX: 913-365-7078  
TOLL FREE 1-800-351-2525 www.trainingtowers.com

**2ND ALARM - STANDARD  
FIRE TRAINING SIMULATOR**  
FIRE DEPARTMENT TRAINING SIMULATOR

THIS INFORMATION CONFORMS TO ALL APPLICABLE STANDARDS FOR THE TRAINING SIMULATORS AT THE TIME OF REVISION.  
THE DESIGN CONTRACTOR ASSUMES RESPONSIBILITY FOR ALL MATERIALS, AT THE TIME OF DELIVERY. THIS CONTRACTOR IS ALSO RESPONSIBLE TO ACCOUNT FOR ALL MATERIALS, AT THE TIME OF DELIVERY. IF THERE IS A DISCREPANCY IN THE MATERIAL RECEIVED, CONTACT THE MANUFACTURER IMMEDIATELY IN ORDER TO MAKE PROPER ARRANGEMENTS TO PROVIDE THE NECESSARY MATERIAL.  
THIS SET OF DRAWINGS IS INTENDED AS A CONCEPTUAL SET, PROVIDED FOR SECONDARY REFERENCE ONLY. REFER TO BUILDER INDUSTRIES CONSTRUCTION DRAWINGS AND THE BUREAU OF STANDARDS DRAWINGS AS PRIMARY REFERENCE FOR EXACT MATERIAL DIMENSIONS, DECORAL AND PROCEDURES.  
THESE DIMENSIONS, SPECIFICATIONS, HEAD, DESIGN, AND FINISHES ARE AND SHALL REMAIN THE PROPERTY OF BIP TRAININGTOWERS AND NO PART THERE OF SHALL BE COPIED, REPRODUCED, OR USED IN CONNECTION WITH ANY WORK OR PROJECT OTHER THAN THE SPECIFIC PROJECT FOR WHICH THEY HAVE BEEN PREPARED WITHOUT WRITTEN CONSENT OF BIP TRAININGTOWERS.

PROJECT NUMBER:	00-W-000	REVISION DATES:
DRAWN BY:	PK	1
REVIEWED BY:	P	2
PRINT DATE:	00-00-00	3
		4

FRONT SIDE AND LEFT SIDE ELEVATIONS

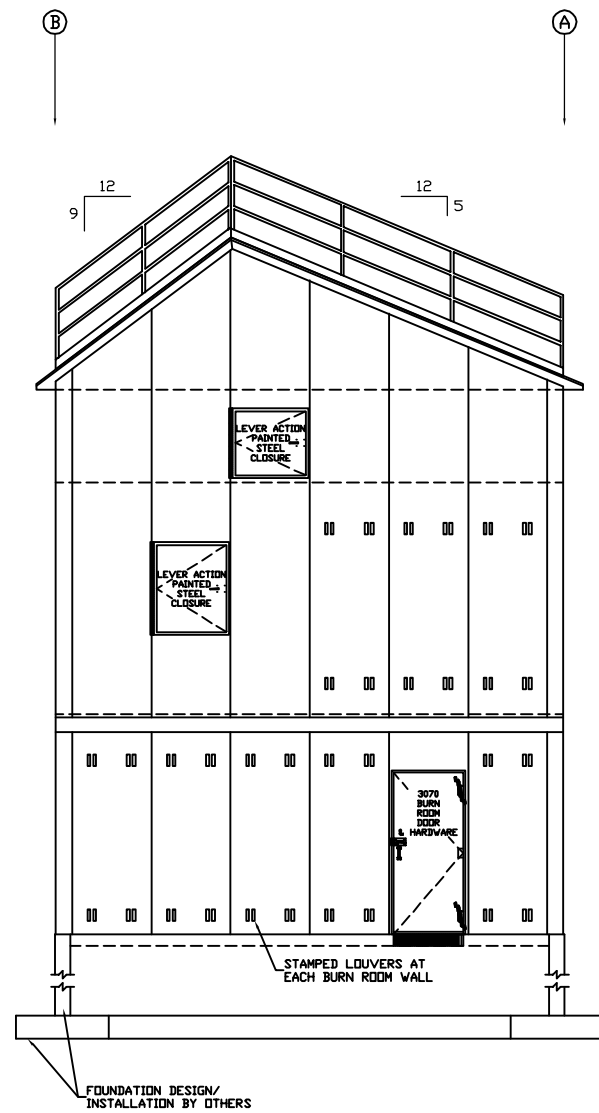

RIGHT SIDE ELEVATION  
NOT TO SCALE

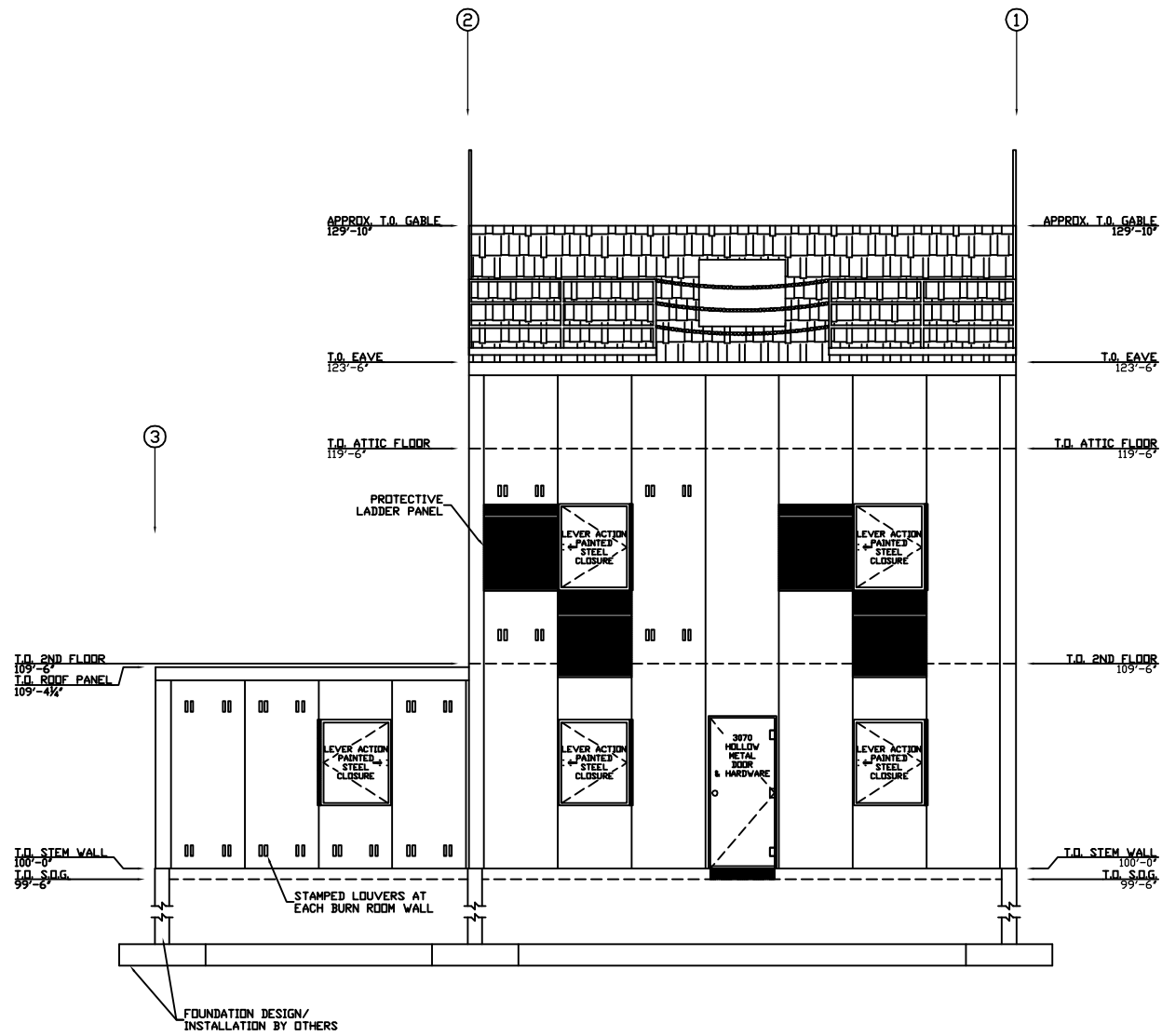

REAR SIDE ELEVATION  
NOT TO SCALE

2ND ALARM - STANDARD  
FIRE TRAINING SIMULATOR

FIRE DEPARTMENT TRAINING SIMULATOR

THIS INFORMATION CONFORMS TO ALL APPLICABLE STANDARDS FOR THE TRAINING SIMULATORS AT THE TIME OF REVISION.  
THE DESIGN CONTRACTOR ASSUMES RESPONSIBILITY FOR ALL MATERIALS, AT TIME OF DELIVERY. THIS CONTRACTOR IS ALSO RESPONSIBLE TO ACCOUNT FOR ALL MATERIALS, AT TIME OF DELIVERY. IF THERE IS A DISCREPANCY IN THE MATERIAL RECEIVED, CONTACT THE MANUFACTURERS IMMEDIATELY IN ORDER TO MAKE PROPER ARRANGEMENTS TO PROVIDE THE NECESSARY MATERIAL.  
THIS SET OF DRAWINGS IS INTENDED AS A CONCEPTUAL SET, PROVIDED FOR SECONDARY REFERENCE ONLY. REFER TO BUILDER INDUSTRIES CONSTRUCTION DRAWINGS AND THE MANUFACTURERS DETAILS DRAWINGS AS PRIMARY REFERENCE FOR EXACT MATERIAL DIMENSIONS, DECORAL AND PROCEDURES.  
THESE DIMENSIONS, SPECIFICATIONS, NOTES, DETAILS AND DIMENSIONS ARE AND SHALL REMAIN THE PROPERTY OF WFP TRAINING TOWERS AND NO PART THEREOF SHALL BE COPIED, REPRODUCED, OR USED IN CONNECTION WITH ANY WORK OR PROJECT OTHER THAN THE SPECIFIC PROJECT FOR WHICH THEY HAVE BEEN PREPARED WITHOUT WRITTEN CONSENT OF WFP TRAINING TOWERS.

PROJECT NUMBER:	00-W-000	REVISION DATES:
PROJECT ERECTOR:	JPK	2
DRAWN BY:	JP	3
REVIEWED BY:		4
PRINT DATE:	00-00-00	

REAR SIDE  
AND RIGHT SIDE  
ELEVATIONS

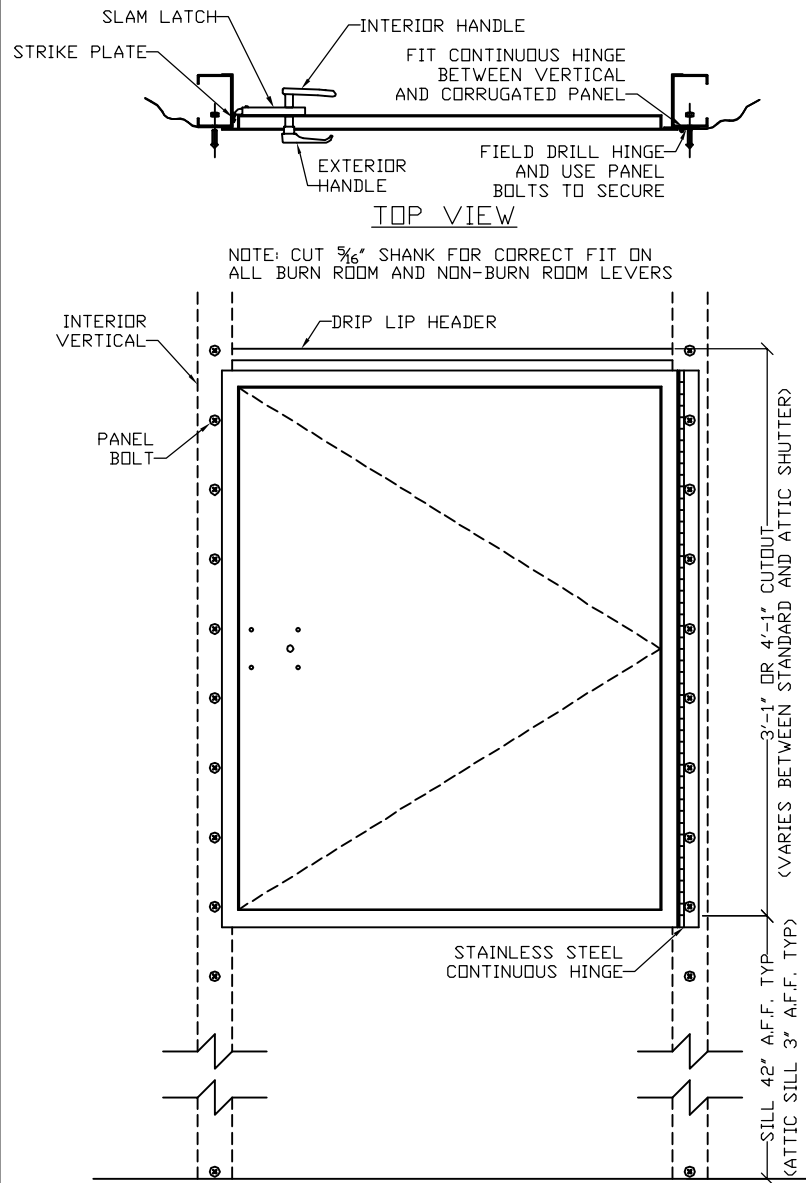

**TOP VIEW**  
NOTE: CUT 5/16" SHANK FOR CORRECT FIT ON ALL BURN ROOM AND NON-BURN ROOM LEVERS

**EXTERIOR VIEW**  
CLOSURE INSTALLATION DETAIL  
NOT TO SCALE

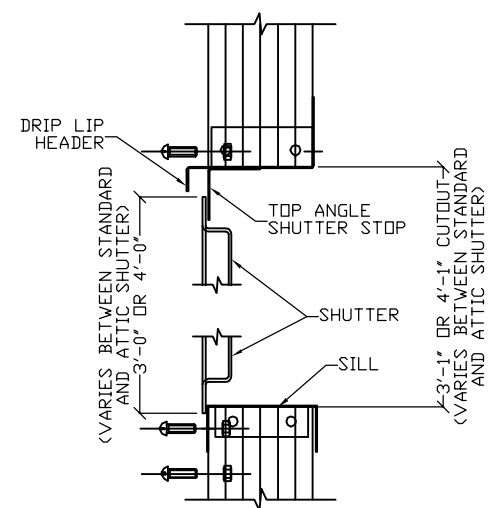

**CLOSURE SECTION DETAIL**  
NOT TO SCALE

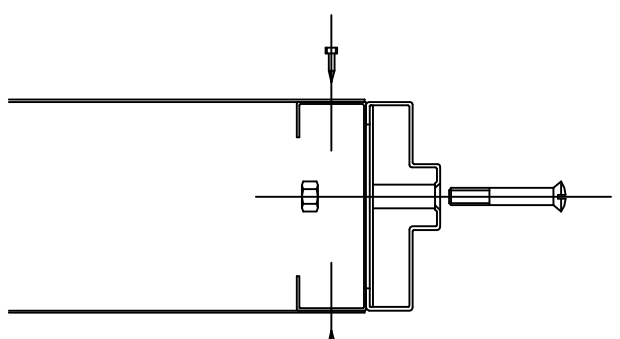

**JAMB @ INTERIOR WALL**  
NOT TO SCALE

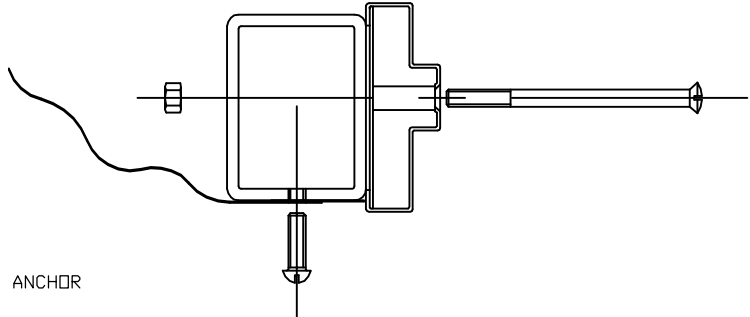

**JAMB @ TUBE STEEL VERTICAL**  
NOT TO SCALE

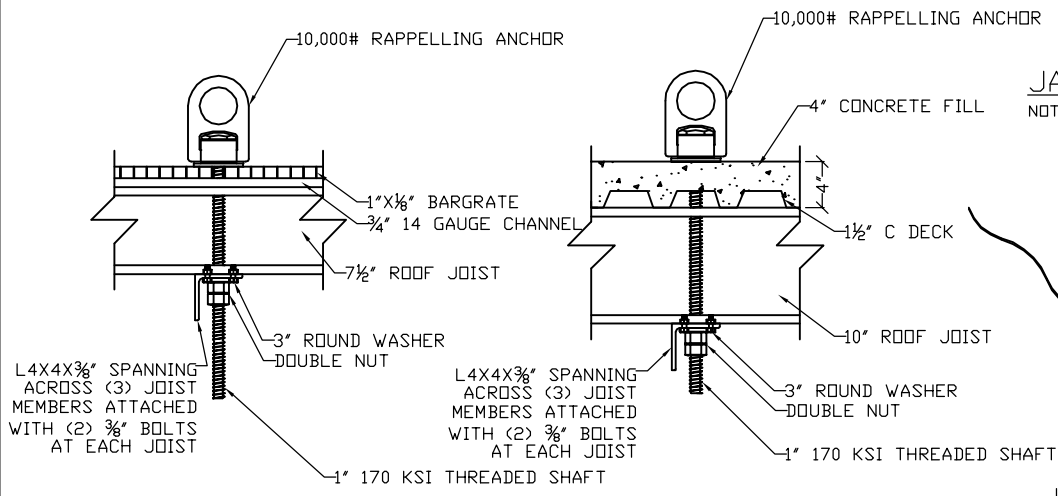

**RAPPELLING ANCHOR INSTALLATION DETAILS**  
NOT TO SCALE

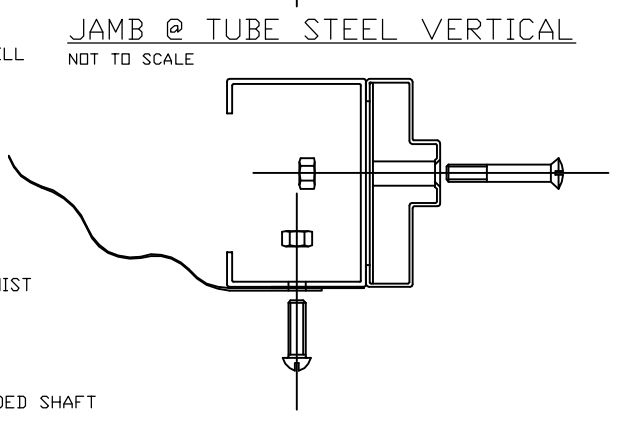

**JAMB @ 12 GA CEE VERTICAL**  
NOT TO SCALE

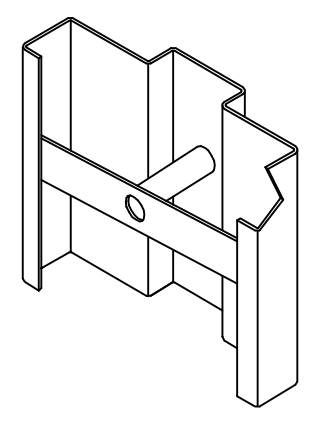

**FRAME ANCHOR ISO**  
NOT TO SCALE

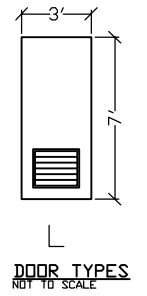
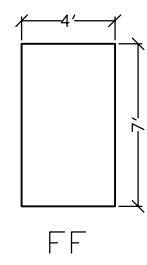
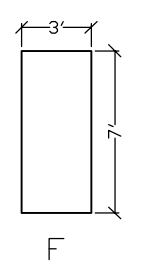

**DOOR TYPES**  
NOT TO SCALE

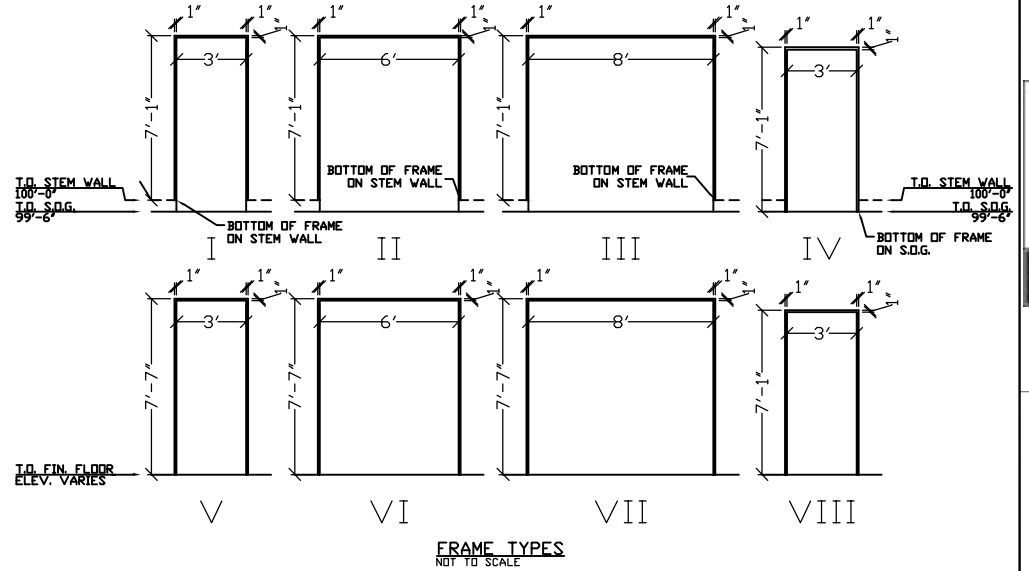

**FRAME TYPES**  
NOT TO SCALE

HARDWARE	HARDWARE SETS											
	H1	H2	H3	H4	H5	H6	H7	H8	H9	H10	H11	H12
SS BUTT HINGE	3	3	3	3	3	3	6	6				
SS CONTINUOUS HINGE									1	1	1	1
LOCKSET	1				1		1					
PASSAGE SET		1				1						
DOOR PULL			1	1				1				
BALL CATCH			1	1				1				
SPRING CLOSE			2	2				4				
BARREL BOLT			1					2				
ASTRIGAL							1	1				
DOOR SWEEP	1	1	1	1			2	2				
SLAM LATCH									1	1	1	1
SLAM LATCH STRIKE									1	1	1	1
INTERIOR HANDLE-STANDARD									1	1		
INTERIOR HANDLE-BURN ROOM											1	1
LOCKING HANDLE									1		1	
NON-LOCKING HANDLE										1		1

OPENING NUMBER	TYPE	APPROXIMATE SHUTTER WIDTH	APPROXIMATE SHUTTER HEIGHT	ROUGH OPENING WIDTH	ROUGH OPENING HEIGHT	SILL HEIGHT A.F.F.	GAUGE	MATERIAL & FINISH	PAINT FINISH	HARDWARE SET	REMARKS
V1	LOCKING NON-BURN ROOM SHUTTER	3'-3"	4'-0"	3'-2"	4'-1"	42"	12	G90 POWDER COAT	H9		
V2	LOCKING BURN ROOM SHUTTER	3'-3"	4'-0"	3'-2"	4'-1"	42"	12	G90 POWDER COAT	H11	PADGENITE INTERIOR FACE	
V3	LOCKING ATTIC SHUTTER	3'-3"	3'-0"	3'-2"	3'-1"	3"	12	G90 POWDER COAT	H9		
V4	NON-LOCKING NON-BURN ROOM SHUTTER	3'-3"	4'-0"	3'-2"	4'-1"	42"	12	G90 POWDER COAT	H10		
V5	NON-LOCKING BURN ROOM SHUTTER	3'-3"	4'-0"	3'-2"	4'-1"	42"	12	G90 POWDER COAT	H12	PADGENITE INTERIOR FACE	
V6	NON-LOCKING ATTIC SHUTTER	3'-3"	3'-0"	3'-2"	3'-1"	3"	12	G90 POWDER COAT	H10		

OPENING NUMBER	ROOM	FROM/TO	QUANTITY	PAIR	WIDTH	HEIGHT	HARDWARE SET	FRAME TYPE	GAUGE	MATERIAL & FINISH	DEPTH	THROAT	JAMB FACE	HEAD FACE	JAMB ANCHORS	DOOR TYPE	GAUGE	MATERIAL & FINISH	REMARKS	
																				REMARKS
101	EXTERIOR	F	SECTION B	1	PR	3'-0"	7'-0"	RHA	H7	II	16	A604-3/4"	3'-3/4"	1"	1"	ED	F	18	A60	
102	EXTERIOR	F	SECTION B	1	--	3'-0"	7'-0"	RHR	H1	I	16	A604-3/4"	3'-3/4"	1"	1"	ED	F	18	A60	
103	SECTION B	F	SECTION C	1	--	3'-0"	7'-0"	LH	H4	I	16	A604-3/4"	3'-3/4"	1"	1"	ED	F	18	A60	PADGENITE INTERIOR FACE
104	EXTERIOR	F	SECTION C	1	--	3'-0"	7'-0"	LH	H3	I	16	A604-3/4"	3'-3/4"	1"	1"	ED	F	18	A60	PADGENITE INTERIOR FACE
201	SECTION B	F	BURN ROOM #2	1	--	3'-0"	7'-0"	RH	H4	V	16	A604-3/4"	3'-3/4"	1"	1"	ED	F	18	A60	PADGENITE INTERIOR FACE

www.trainingtowers.com  
A DIV. OF J.S.C. INC.  
9121 BOND OVERLAND PARK, KS 66214  
TEL 913-365-3663 FAX: 913-365-7078  
TOLL FREE 1-800-351-2525 www.trainingtowers.com

**2ND ALARM - STANDARD  
FIRE TRAINING SIMULATOR**

FIRE DEPARTMENT TRAINING SIMULATOR

THIS INFORMATION CONFORMS TO ALL APPLICABLE STANDARDS FOR THE TRAINING SIMULATORS AT THE TIME OF REVISION.  
THE DESIGN CONTRACTOR ASSUMES RESPONSIBILITY FOR ALL MATERIALS, AT THE TIME OF DESIGN. THIS CONTRACTOR IS ALSO RESPONSIBLE TO ACCOUNT FOR ALL MATERIALS, AT THE TIME OF REVISION. IF THERE IS A DISCREPANCY IN THE MATERIALS, CONTACT THE DESIGN CONTRACTOR IMMEDIATELY IN ORDER TO MAKE NECESSARY ARRANGEMENTS TO PROVIDE THE NECESSARY MATERIAL.  
THIS SET OF DRAWINGS IS INTENDED AS A CONCEPTUAL SET, PROVIDED FOR SECONDARY REFERENCE ONLY. REFER TO BIDDING DOCUMENTS, CONSTRUCTION DRAWINGS AND THE BIDDING DOCUMENTS FOR PRIMARY REFERENCE. FOR EXACT MATERIAL, DIMENSIONS, DECIMALS, AND PROGRAMS.  
THESE DIMENSIONS, SPECIFICATIONS, MATERIALS, AND FINISHES ARE AND SHALL REMAIN THE PROPERTY OF THE CONTRACTOR AND NO PART THEREOF SHALL BE COPIED, REPRODUCED, OR USED IN CONNECTION WITH ANY OTHER PROJECT OR FOR ANY OTHER PURPOSE WITHOUT THE WRITTEN CONSENT OF THE CONTRACTOR.

PROJECT NUMBER:	00-W-000	REVISION DATES:
PROJECT ERECTOR:	JPK	1
DRAWN BY:	P	1
REVIEWED BY:		
PRINT DATE:	00-00-00	4

WINDOW CLOSURE DETAIL,  
DOOR DETAIL, SCHEDULE,  
AND RAPPELLING ANCHOR DETAIL